

**SUN KID – WONDERCARPET – BELT  
SKD18 - 2013 - 1,2m/s  
DAILY CHECKLIST FOR 100 DAYS OF  
OPERATION**



**SunKid GmbH**  
**A - 6460 Imst/Tirol**  
 Tel (+43) 05412.68131  
 Fax (+43) 05412.68132  
 e-mail: [office@sunkid.at](mailto:office@sunkid.at)  
 Website: [www.sunkid.at](http://www.sunkid.at)  
**UID-Nr: ATU42030100**

OPERATING SEASON

OWNER:

TYPE:                      LENGTH:                      MOTOR:                      YEAR OF  
 MANUFACTURE:

IF PROBLEMS - CONTACT:

**WEEKLY TEST (7 DAY PERIODE)**

- Carefully de-icing under the driving and return drum.
- Assurance that the conveyor belt is properly tensioned and operates smoothly
- Test of the back-stop (it must not move in the locked direction)
- Check the abrasion of the belt and guide lines. Pay attention to loosen screws.

On	Date	Completed by:	Problems/check
Problems Contacted at checks			

Duration of daily „ABC“-check: dependent on the length of the belt: 3 – 5 minutes.  
 Yearly maintenance and gear oil change: see manual

**DAILY CHECK BEFORE OPERATION**
**ABC-TEST**
**A 1) Test Transition Stop device (speed max. 1,2m/s)**

Use the little finger to check the functionality of the transition stop device (TSD). It must switch off the belt at the latest when the gap is 20mm. (stopping distance max. 80cm)  
 An opening of more than 60mm releases the second transition stop device (TSD2) and opens a gap of min. 50cm. (stopping distance max. 40cm). TSD should be closed tight during operation and must not be iced up.

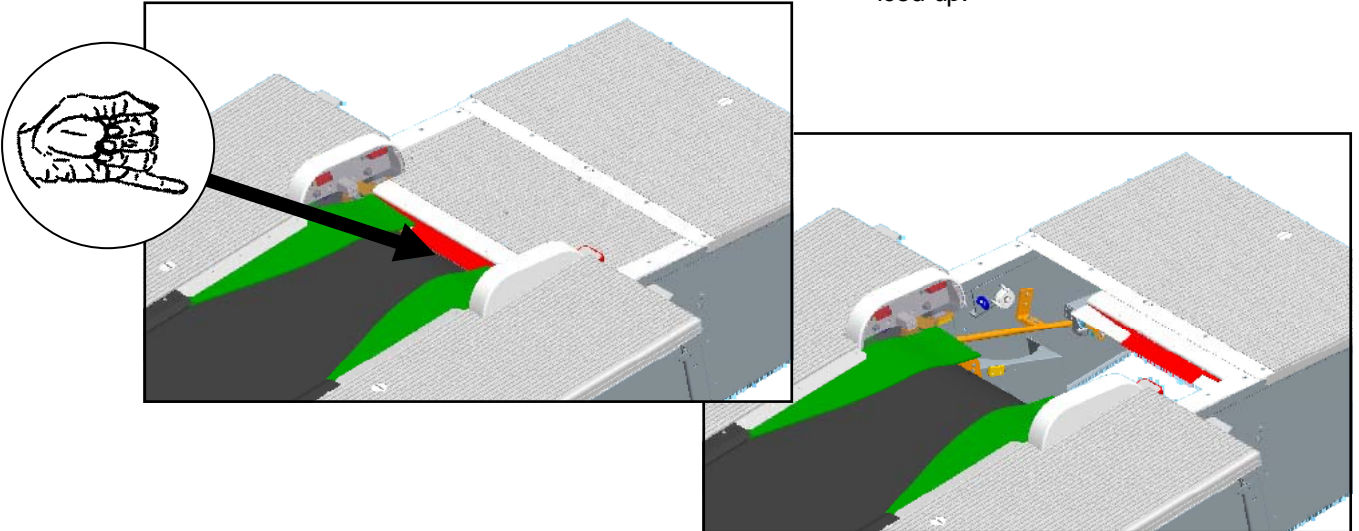
**2) Test Transition Stop device (speed max. 0,7m/s)**

Use the little finger to check the functionality of the transition stop device (TSD). It must switch off the belt at the latest when the gap is 20mm (stopping distance max. 20cm) then open up a min 60mm wide gap. If necessary the second transition stop device can be unlocked by the unlock lever.

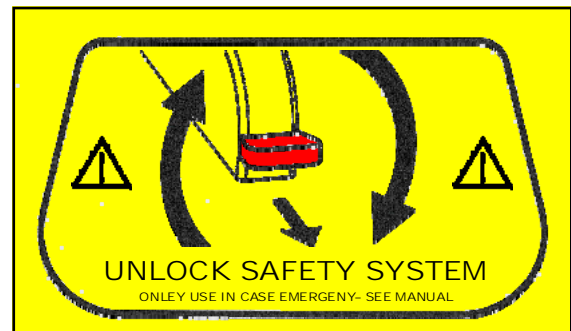
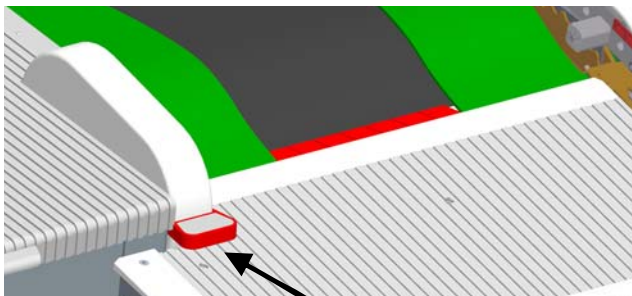
**3) Mechanical adjustment—max. speed 0,7m/s or 1,2m/s**

Remove the splint (1) and move the lever rod (2) either to left or right position:  
 -left position 0,7m/s      -right position 1,2m/s  
 Afterwards put in splint (1) again.

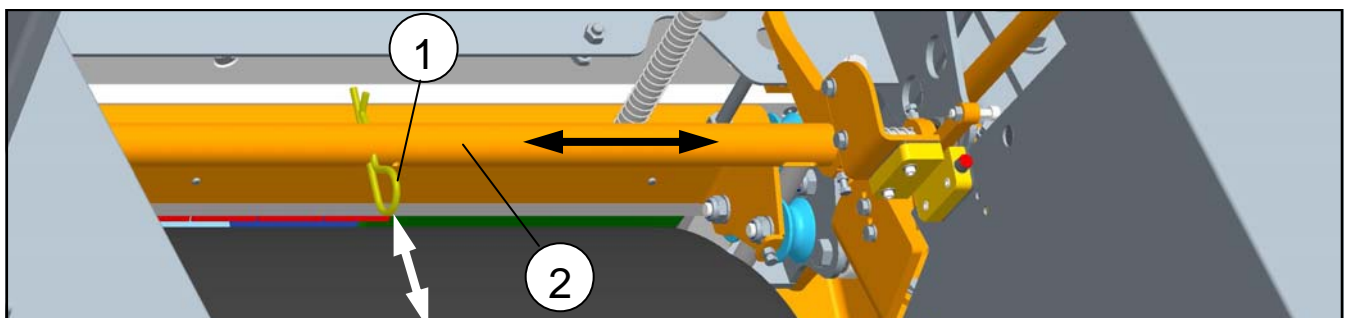
**4) Check Emergency stop buttons**

Test all emergency stop buttons. Conveyor must stop immediately.

**DAILY CHECK BEFORE OPERATION**
**ABC-TEST**
**5) check Safety net**

The safety net (or foam block) underneath the transition stop device must be checked for obvious damage. In case of any injury of the net or its fixation it must be repaired before belt can be operated. If the net was stressed (e.g. by a person falling into it) an exceptionally inspection must be made.

No obstacles must be stucked onto the net.

The net must be renewed **every three years**.

If no snow pit is installed, it isn't necessary to install a safety net.

**6) check foam block**

The foam block which is installed in the area below the transition stop device should

- have a distance between less than 40cm,
- be fixed at least on one side to prevent a take in from the belt,
- free off dirt or snow collection and
- take no negative influence on the function of the transition stop device.

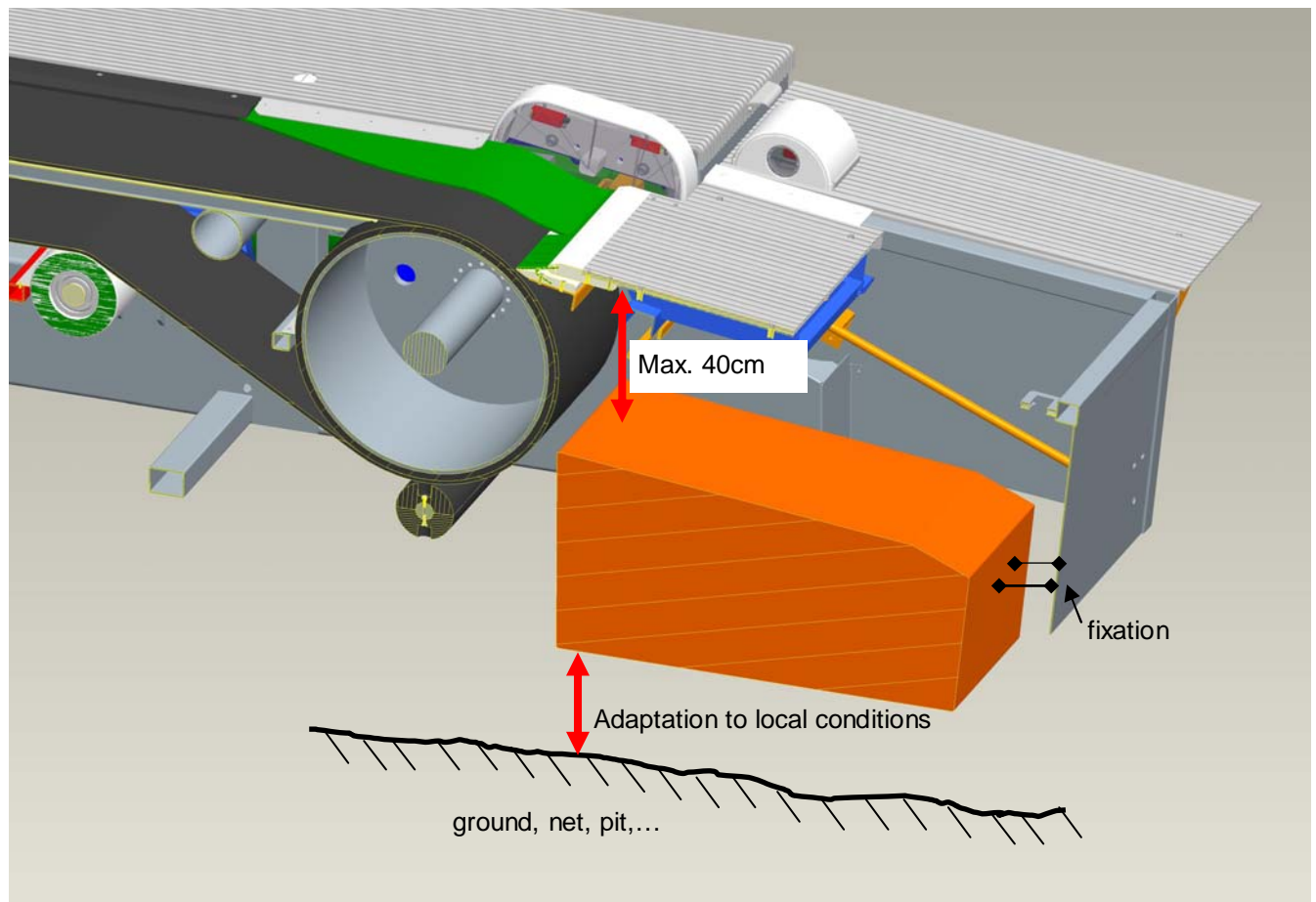

**DAILY CHECK BEFORE OPERATION**
**7) Test Overspeed**

Overspeed supervision must stop the conveyor immediately if speed exceeds a level of 110% of max. speed.

**B Belt Surface Check:**

Let the belt complete a full revolution. The belt must form a closed surface.

- Check for smooth, clean movement at the belt centre.
- Check the belt connection for damage. The bent ends of the connecting wire must face away from the direction of travel and be located within the edge of the belt.
- The transition to the snow surface at the entrance and exit must not have any holes or gaps and must be at a slight downwards slope.
- The lateral free space with an overall width of at least 2m over the level of the conveyor belt must be checked daily before commissioning. This free space must be arranged symmetrical to the belt centre.
- Remove any snow from beneath the belt infeed and point of redirection as necessary.
- The belt must not become so icy that passengers start to slide backwards.
- All covers must be in their correct positions.
- Check the belt's bearing points. Make sure the structure does not wobble or show other signs of instability when it is mounted. The conveyor system must be switched off if it slips out of place or slants at an angle and is no longer stable.

**C „Wonder Carpet Eye“ light barrier (not applicable to the „side exit“ option)**

Test: cover up the light source: the belt must stop moving after 2 seconds.

**MEASURES**

In the event safety features no longer function properly or damage to the belt surface is detected, **stop operations immediately** and have the belt repaired by a qualified technician.

If the light barrier is momentarily out of service, make sure the belt infeed area is placed under direct supervision to ensure the system can be switched off in the event of a fall or accident.

This inspection may have to be carried out more often or even hourly in the event of heavy snowfall or extreme weather conditions (freezing rain). In extreme conditions it may be necessary to permanently monitor and clear the entrance and exit points.

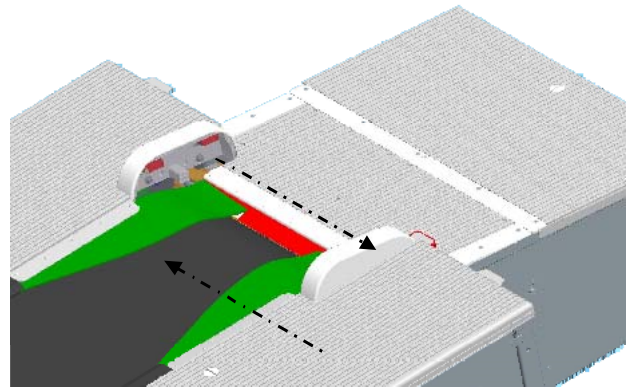
**CHECK LIST: (Mode 1,2m/s)**

1. The belt must stop if the switching plate is opened 20 mm or more.
2. With a max. gap of 60mm, the second transition stop device must open a gap of 50cm.
3. Maximum gap between conveyor belt and cover: 6 mm. Minimum gap: 1 mm.
4. Functionality check for all stop and emergency stop switches.
5. Check the entire belt surface - it must not display any damage.
6. The ends of the connecting wire must be bent back at right angles against the direction of travel and must not protrude beyond the width of the conveyor belt.
7. The belt must stop after 2 seconds if the light barrier is covered up.
8. The side cover along the conveyor belt must prevent the access to/under the construction.

**CHECK LIST: (Mode 0,7m/s)**

1. The belt must stop if the switching plate is opened 20 mm or more.
2. 60 mm – switching plate opens fully.
3. Activation of the emergency handle and opening the second plate to 50cm .
4. Maximum gap between conveyor belt and cover: 6 mm. Minimum gap: 1 mm.
5. Functionality check for all stop and emergency stop switches.
6. Check the entire belt surface - it must not display any damage.
7. The ends of the connecting wire must be bent back at right angles against the direction of travel and must not protrude beyond the width of the conveyor belt.
8. The belt must stop after 3 seconds if the light barrier is covered up.
9. Overspeed supervision must stop the conveyor if speed exceeds max. speed.
10. The side cover along the conveyor belt must prevent the access to/under the construction.



**ANY DAMAGE HAS TO BE REPAIRED IMMEDIATELY!  
OTHERWISE YOU RISK SERIOUS ACCIDENTS WITH INJURY TO PERSONS!**

If o.k. ✓	Prior to operation			Prior to after-noon operation (after 3 h)			C*Option monitoring-eye, if installed	If o.k. ✓	Prior to operation			Prior to after-noon operation (after 3 h)			C*Option monitoring-eye, if installed		
	Date	A	B	C*	A	B	C*		Name Tester Signature	Date	A	B	C*	A	B	C*	Name Tester Signature

Problems:  
Date:

If o.k. ✓	Prior to operation			Prior to after-noon operation (after 3 h)			C*Option monitoring-eye, if installed	Name Tester Signature	If o.k. ✓	Prior to operation			Prior to after-noon operation (after 3 h)			C*Option monitoring-eye, if installed	Name Tester Signature
	Date	A	B	C*	A	B				C*	Date	A	B	C*	A		

Problems:  
Date: