

DAILY CHECK BEFORE OPERATION

ABC-TEST

A Check all safety devices

1. Transition Stop Device

Using the little finger, check the function of the Transition Stop Device. Belt must stop with 4 - 6mm (1/6"-1/4") of travel. Once the stop has been initiated, the Transition Stop Device shall move freely and without obstruction until it is hidden under the unloading plate.

2. Transition stop reset

If Transition stop device opened once conveyor must not start until it is unlocked by reset device

3. Test emergency plate

If emergency plate is moved more than 30mm out of its position belt must stop. Area underneath emergency plate must be kept free from ice and snow

4. Check emergency stop (emergency shutdown):

Test the function of all Stop-buttons. The belt must stop!

B Belt surface check:

Operate the belt for at least one complete revolution, check for the following and correct as necessary:

- That no tears, rips or punctures of the belt have developed.
- That the belt tracks smoothly in the centre of the drum with minimum side to side movement.
- That no wires or metal pieces stick out from the splice coupling area.
- That no excessive gaps or holes exist between the snow and carpet walkways or between the belt and carpet walkways.
- That the structural integrity of the carpet-frame has not changed. With the carpet stopped, walk down the centre and check for excessive flex, bending and instability in the frame.
- That snow and ice build-up under the drive and return drums have not occurred.
- That the loading ramp to the belt is maintained level for 2-3 meters ahead of the belt.
- That the unloading ramp is slightly sloping away from the belt for 1,5 - 2 meters.
- That excessive build-up of snow and or ice on the carpet hasn't developed that could cause an user to slide backwards.
- That each carpet walkway is securely in place and locked down.

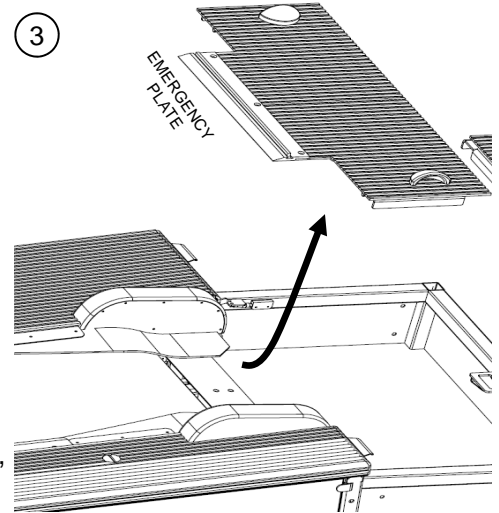
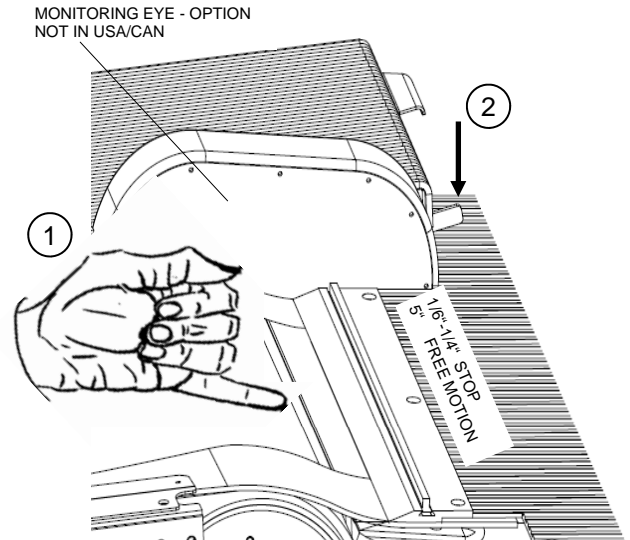

ARRANGEMENT

In case of belt damage, or a failure in the safety system **stop the belt immediately**, until a qualified person repairs it.

CHECK LIST:

1. Belt must stop after 4 - 6mm of travel of Transition Stop Device .
2. 130 mm – 5" smooth moving of the Transition Stop Device.
3. Between the belt and all covering parts (rubber, plastic, wooden covers) a maximum gap of 6 mm is permitted (min. gap 1 mm - 1/25")
4. Belt must stop after pressing any Stop button.
5. Max. speed – stop – max. stopping distance permitted is 300 mm (12").
6. Monitor one complete revolution of the belt and check for damage.
7. The ends of the splice rods should be bent in a 90° angle in the opposite direction of belt travel. The bended ends must be inside the belt edge.



**Any damage has to be repaired immediately!
Otherwise you risk serious accidents with injury to persons!**

